



MEEVER BRACING



MEEVER GROUP

INSTALLATION INSTRUCTIONS

Strut S1000

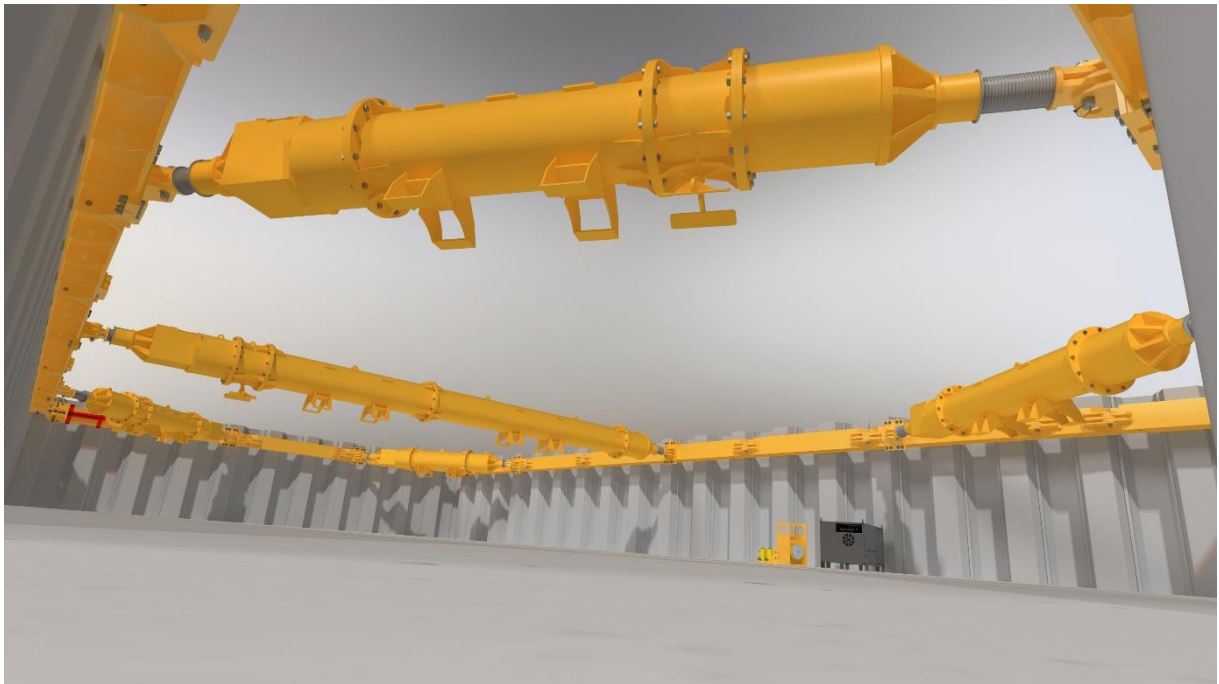



THINK SAFETY, ACT SAFELY!

Safety rules shall always be maintained.

Safety always comes first.



Table of contents:

1	Introduction	3
2	System elements and connections	4
3	Product notes	4
4	Installation	5



1 Introduction

Heavy duty modular strutting systems that are designed to be used as cross struts with the Meever Bracing system. The S1000 Strutting system can also be used to prop reinforced concrete piles and capping beams. Each strut comprises a hydraulic ram and mechanical units together with various lengths of strut extension bars.

The S1000 strutting system can support loads of up to 1000kN SWL and span up to 14.0m. Components are very heavy and are normally assembled on site prior to being lifted into place and installed within the excavation using heavy cranes. Handling points are provided at regular intervals on each leg to assist assembly and removal. Struts are normally long and unbalanced (due to the weight of ram/jack unit) and great care must be taken in preparing the lift / maintaining lift angle (tag lines strongly recommended).

Fabricated from grade S355 300x300x12 square steel section, the extensions are quickly assembled into the required strut lengths using bolts, nut and washer assemblies. Final adjustment is provided by a mechanical strut end providing up to 650mm of stroke and a hydraulic strut end providing a 100mm stroke for fine adjustment. Once located at the correct position the struts are pre-loaded (or tightened) against the face of the brace to be supported using a hydraulic pump on the ram. Preloading of the legs ensures the strut cannot slip, takes up any slack in the system and minimizes the extent of potential ground movements.



2 System elements and connections

S1000 Strutting System	
Component	Weight [kg]
Support plate	62
Hydraulic end	302
Mechanical end	128
0,5m extension	95
1m extension	149
2m extension	259
3m extension	368
5m extension	586

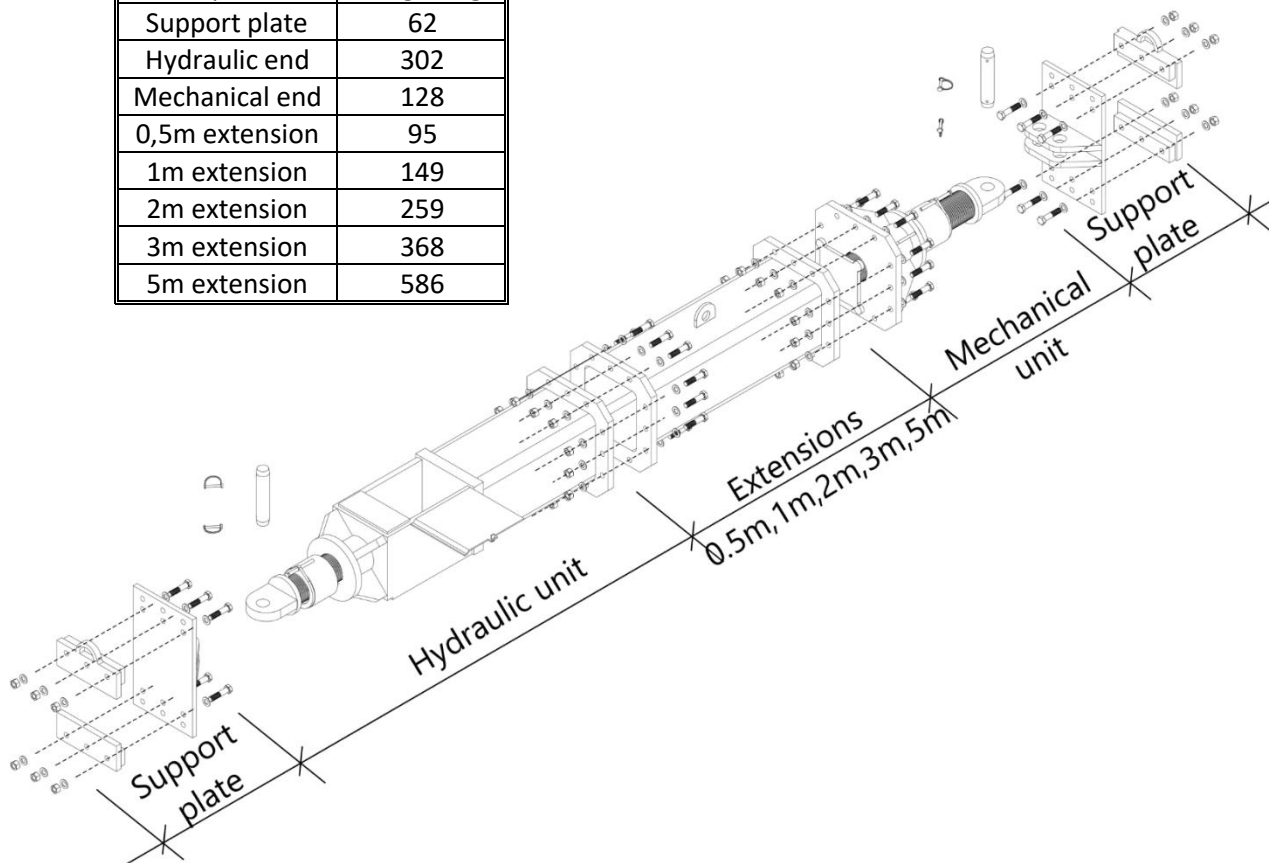

3 Product notes

1. Strut systems are very heavy and should only be assembled, installed, and removed by competent personnel.
2. Installation is normally carried out by assembling the complete strut and then lowering into place (subject to crane / excavator capacity). Struts are normally long and unbalanced (due to the weight of ram/jack unit) and great care must be taken in preparing the lift / maintaining lift angle (tag lines strongly recommended).
3. Struts are to be fully pre-loaded or tightened, all hydraulic units to be secured prior to releasing hydraulic jack and lifting chains from strut and commencing works. When assembling on site ensure that all nuts and bolts are in place and secured and all plate



bolts are installed and fully tightened / torqued with a minimum two threads visible beyond the nut.

4. Each individual component should be visually inspected for damage before entering the excavation.
5. Edge protection should always be considered for every excavation for personnel safety.
6. Prior to removal the complete strut must be independently supported. Once this is accomplished the hydraulic rams (or struts) must be released and retracted to avoid the need for excessive extraction forces.
7. When installing struts at angles, you must be sure that the angles match the design, all shear stops are in place and all elements are supported/packed and capable of transmitting loads effectively. On large unsupported spans the pre-load must be applied prior to removing lifting chains to avoid sagging.

4 Installation

Perform the installation according to bracing layout supplied with the system!

Note: When installing corner strut, the support plates need to be protected against displacement. Check the bracing design for details to ensure correct protection.

1. Assemble mechanical end, hydraulic end and extension pipes with 12 bolts M20x90 grade 8.8 per flange. Recommended tightening torque 410 Nm.

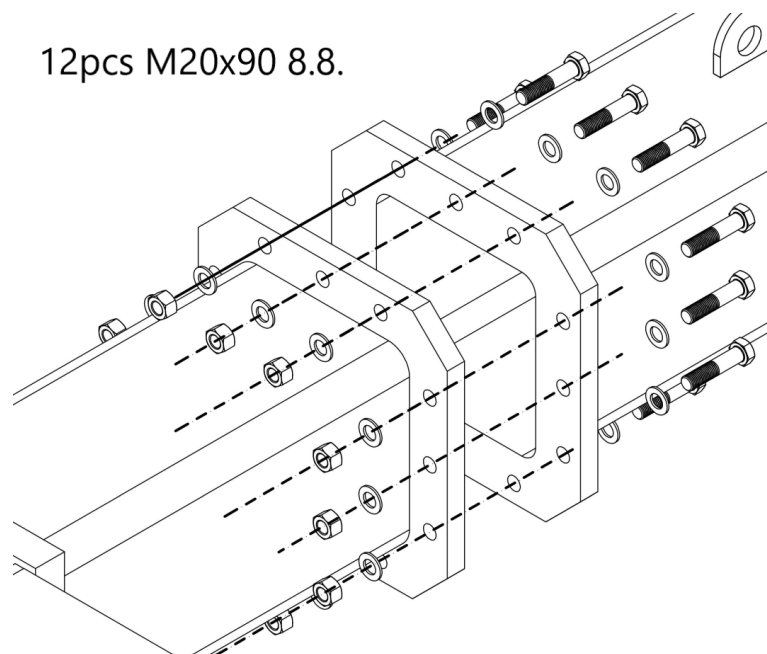

- Remove bottom clamps from support plates at both ends of the strut.

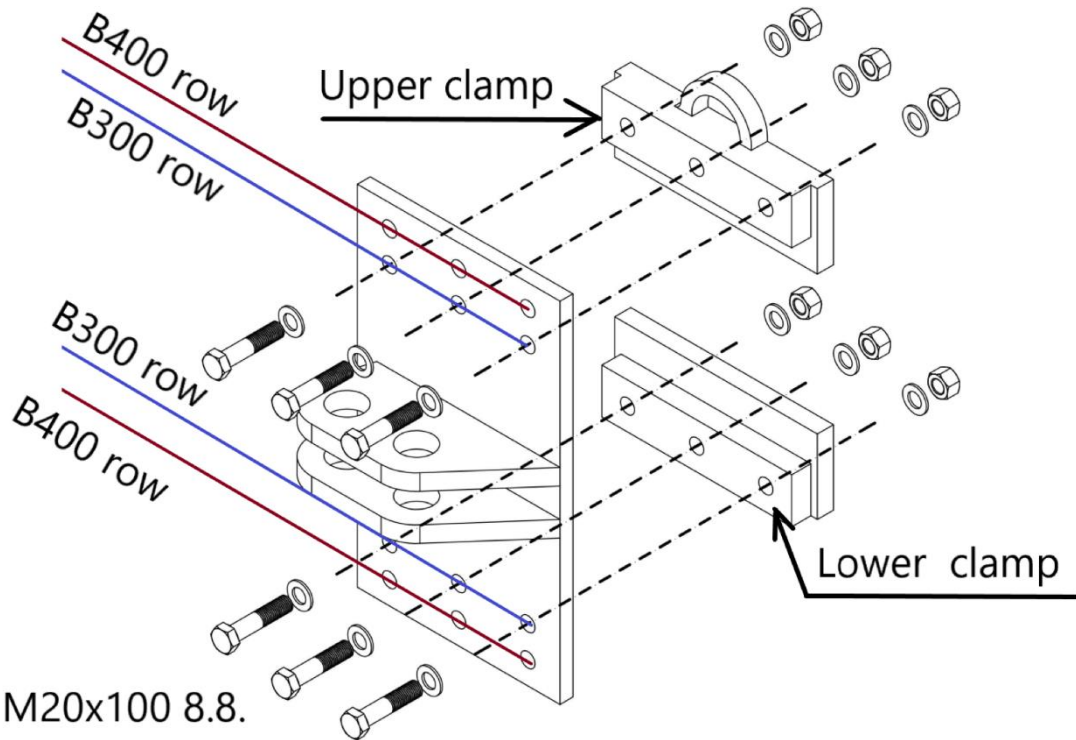

- Before installation to excavation, please ensure that there is minimum 50-60 mm of free thread on Hydraulic Unit ending. This free thread is crucial for system removal as it will be needed to compensate shoring deformations.



- Attach support plates to the beam. Ensure that clamps are attached to support plate on the right bolt holes line to match beams properly. Screw back bottom clamps to support plates at both ends of the strut with 6 bolts M20x100 grade 8.8 per plate.
- First, connect Mechanical unit with support plate with 50mm pin. Secure pin with retaining clips.
- Crowbar might be used to extend Mechanical Unit, at the same time the Hydraulic Unit must be connected with support plate.

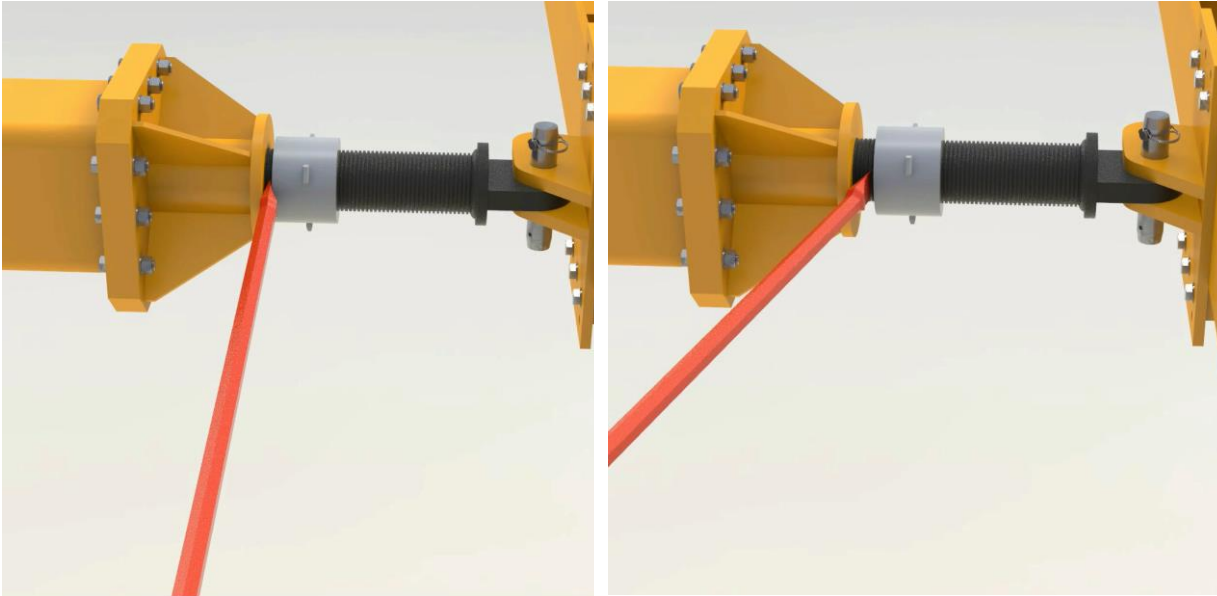

7. Lock the threaded bar at mechanical end with locking nut.

M12x180 locking nut

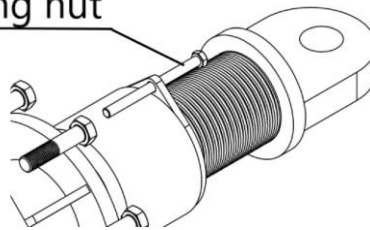

8. Insert hydraulic cylinder into hydraulic end socket.
9. Connect the hydraulic hose and the pump.
10. Pump the cylinder to preload the strut to demanded level. Max. pre-load pressure of 20 Bar must not be exceeded unless design states otherwise.
11. Lock the threaded bar at hydraulic end with locking nut.

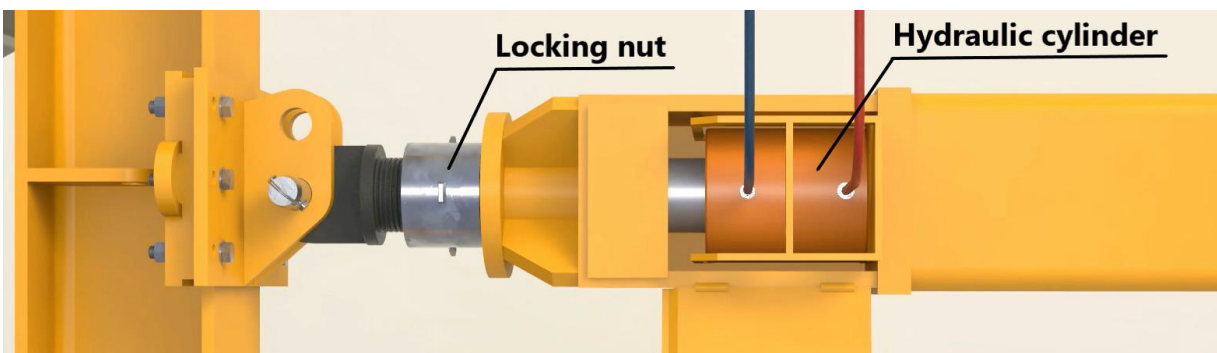

12. Switch the pump valve and pump the cylinder back for full retract.
13. Disconnect the cylinder.
14. Remove the hydraulic cylinder from the socket.
15. We advise to protect threaded bars at both ends with stretch foil against dirt and concrete.



Removal

1. Insert hydraulic cylinder into hydraulic end socket.
2. Connect the hydraulic hose and the pump.
3. Pump the hydraulic cylinder until the locking nut is loose.
4. Turn the locking nut towards the support plate.
5. Switch the pump valve and pump the cylinder back for full retract to release the load.
6. Disconnect the cylinder.
7. Remove the hydraulic cylinder from the socket.
8. Attach lifting chains to the strut lifting point and lift strut a little to ease pin removal.
9. Remove pins connecting strut with support plates.
10. Lift up and take the strut out of the excavation.
11. Remove bottom clamps from support plates at both ends of the strut.
12. Lift support plates and take them out of the excavation.
13. Screw back bottom clamps to support plates at both ends of the strut.

DO

- Check the capacity of lifting equipment
- Protect the strut from accidental strikes
- Check overall strut alignment after installation

DO NOT

- Laterally load the strut
- Impact the strut
- Allow debris and ground to accumulate on the strut
- Pollute threaded bar with the concrete
- Remove the strut under load

IF IN DOUBT – ASK!